

BONUS

New coloring pages,
games, and more!

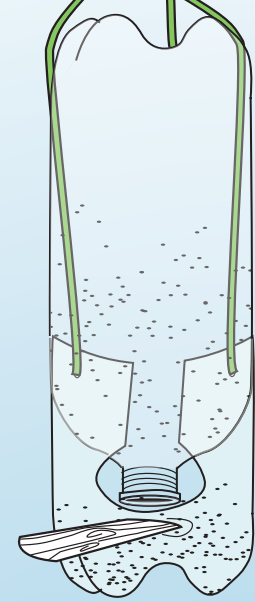
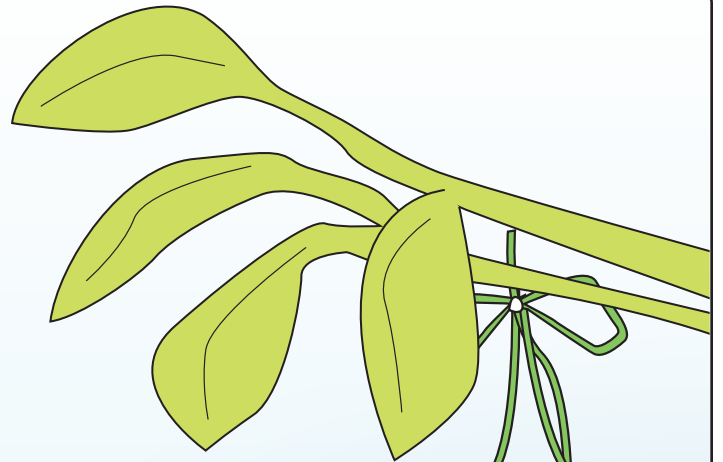
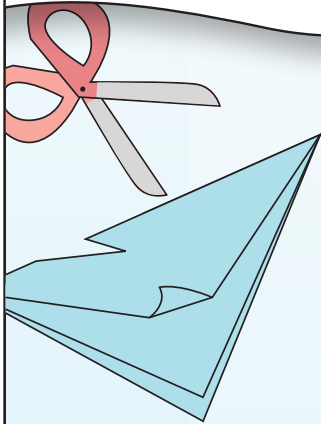

100

FREE

things to do
with your
grandkids

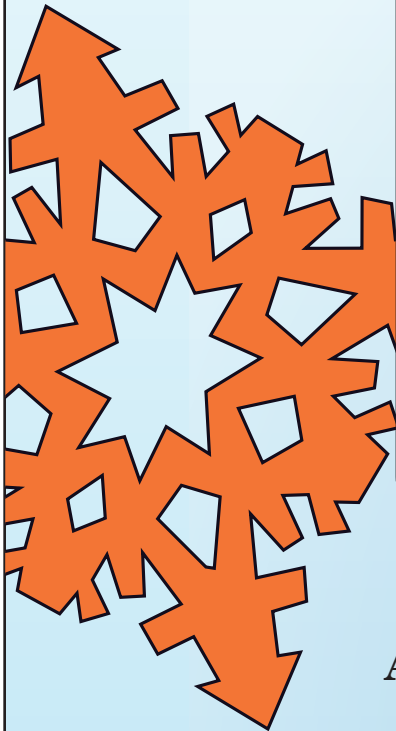

A field guide to more smiles,
more fun, more memories.

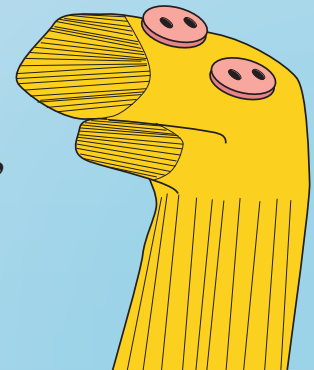

grandparents.comSM
it's great to be grand.

Memories of a lifetime are made from the simplest pleasures, ones that don't necessarily include buying a \$50 personalized teddy bear or a \$200 video game system.

Here at Grandparents.com, we brainstormed and came up with a list of 100 free things to do with your grandchildren of all ages. You might need some materials – like construction paper, paint, uncooked pasta, or an old shoe box. But, for the most part, these activities are free, or really low-cost, and are the little diversions in life that make the bond between you and your grandchildren even stronger.

Who We Are:

Grandparents.com is the premier community for a new generation of active, involved grandparents to foster connections with their grandchildren and their adult children. You'll find child- and grandparent-friendly activities, expert advice, gift ideas, deals, and more, including information on how to get more from all aspects of your life.

In addition, you can connect easily and safely with other grandparents on a variety of topics in our Groups section, enter your grandchild's photo in our ongoing photo contests, and find simple meal ideas the whole family will love in our Recipes section. A free newsletter reveals the best of the site twice each week; to sign up, go to grandparents.com/newsletter.

A field guide to more smiles,
more fun, more memories.



grandparents.comSM
it's great to be grand.

#1 Shoebox Dollhouse

This project can be as simple or elaborate as you choose to make it. First, decide how many rooms (one shoebox per room) you want the dollhouse to have. Cut squares in the bottom of the box for windows. Add miniature furniture and decorations. Put the boxes in the order you want the rooms and glue them together. Take two of the box tops and lean them against each other over the house. This creates a vaulted ceiling and an attic space above the rooms.

#2 Pinhole Camera

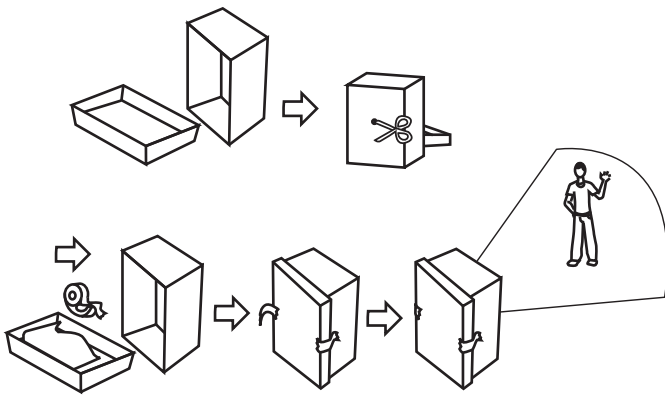

One of the coolest things your grandchild will ever make is a pinhole camera, and it's a great introduction to the fundamental elements of [photography](#). You'll need a sturdy box, one you don't mind making a pinhole in, with a lid that keeps out all light. The Kodak website has comprehensive instructions for making the most of this project. Get more information at [kodak.com](#).

#3 Shoebox Guitar

An easier project than you might think. Take a shoebox and cut a hole in the center of the lid. Now cut a hole on one side of the box. In that hole, put an empty paper towel roll and tape it in place. This makes it look like the long end of a guitar. Take four or five rubber bands of various widths and lengths, and stretch them lengthwise over the lid, as shown.

[3 more musical instruments to make »](#)

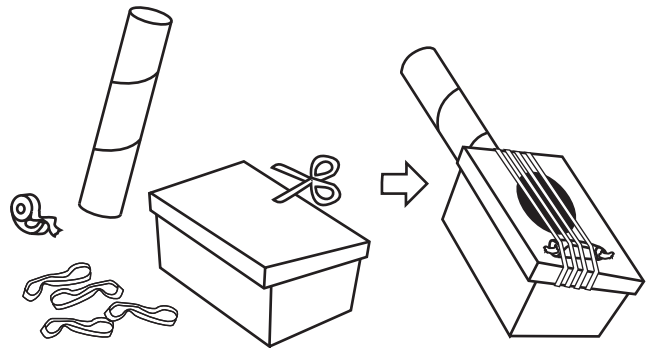

CHITCHAT:

What are the different sounds the rubber bands make when plucked?

A field guide to more smiles,
more fun, more memories.



[grandparents.com](#)SM
it's great to be grand.

#4 Write a Letter to an Elected Official

Children, these days, have a lot on their mind, no matter how old they are. Encourage your grandchildren to express their concerns about life, the environment, gas prices – or even just to say “great job” (if that’s how they feel) – by writing to the President, your local senator, or representative. You can find addresses for everybody from the President to state legislators at whitehouse.gov.

TIP: In many cases, even if it’s just a form letter, the President’s office writes back. Your grandchild will be thrilled with the reply.

#5 Paper Snowflakes

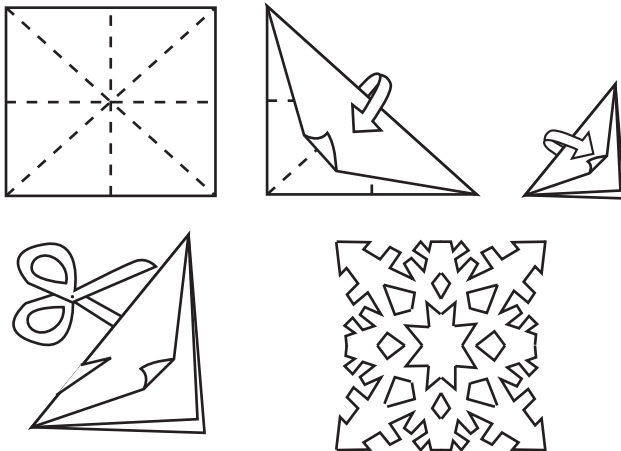

Fold a square piece of paper in half diagonally. Cut small sections out all over the paper and round off the corners of the paper. The bigger the cuts you make and the shapelier the cuts are, the more flair our snowflake will have. Fold the paper in half again, and take another few cuts out of it in a different spot. Fold the paper again, and carve another shape or two into the edges. Make a few final cuts, and unfold the paper to see your snowflake.

[Get more winter craft ideas »](#)

#6 Board Games

Take your pick. On a rainy day, or at the end of a long day, sit down and play a game of Monopoly, or Chutes and Ladders, or Sorry, or Life, or ... need we go on?

Love games? We have seven simple games you can play with just a pen and paper.

[Get them now »](#)

A field guide to more smiles,
more fun, more memories.



grandparents.comSM
it's great to be grand.

#7 Make a Mini-Proscenium

A proscenium is a fancy word for a theater space with an archway at the front of the stage, through which the audience views the play. You can make a small one, scaled to the size of sock puppets ([see #28](#)), by carving an arch into a large cardboard box. Use a flashlight or small clamp lamp as the spotlight. And then, of course, it's time to put on your puppet show.

#8 Play Sardines

A twist on hide-and-seek: Everyone seeks while one hides. As seekers find the person hiding, they hide with him. The last person to join the group is the odd man out. [Get the full rules »](#)

More fun indoor games:

- [Hot-and-Cold](#)
- [Musical Chairs](#)
- [Seven Up](#)

#9 Bowling Alley With Bottles

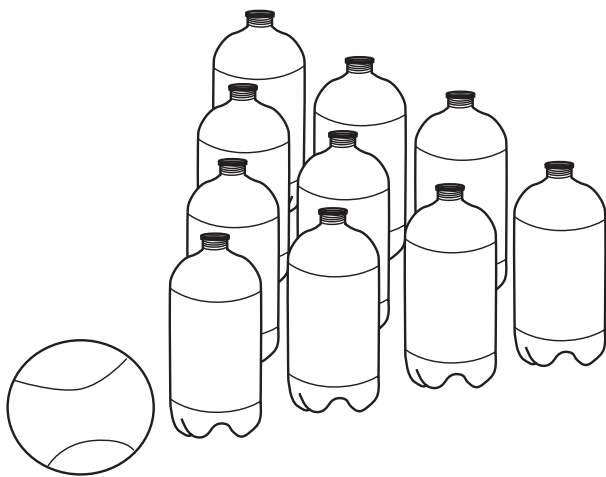

FUN FACT: Dutch colonists brought bowling to the United States in the 17th century. It was regularly played in an area of New York City still known as Bowling Green.

You'll need one round, heavy ball, such as a basketball or a soccer ball, and ten empty plastic bottles. Fill each bottle about one quarter-full with sand or water, making them just heavy enough to stand up but just light enough to be knocked down by the ball. Cap the bottles tightly. Find an area for your alley, like a driveway, a flat, grassy area, or even a long, furniture-free hallway in the house. Set up the bottles in the traditional bowling pin grid: Place one pin up front, two behind that, three behind those, and four in the back. [Get more creative ideas for backyard fun »](#)

A field guide to more smiles,
more fun, more memories.



grandparents.comSM
it's great to be grand.

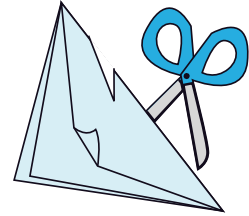
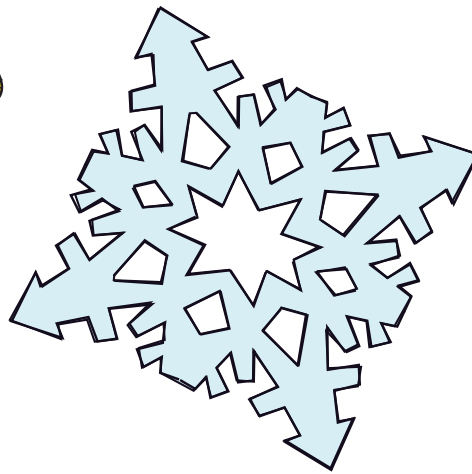
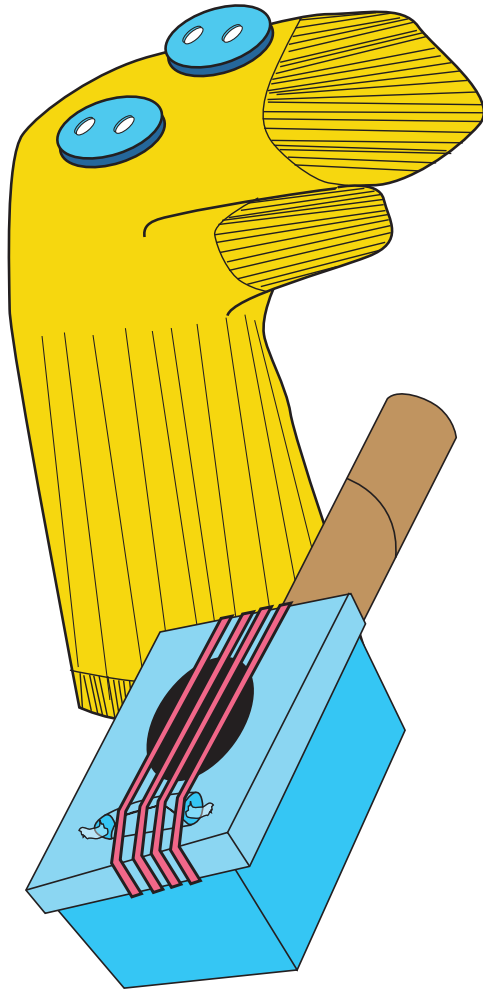

Hey – Don't Keep the Fun to Yourself!

Activities like these are meant to be shared. Send this guide along to your friends, your grandkids' parents – anyone!



Click here to share the guide:
grandparents.com/share101

#10 Make a Mobile

If you have wire hangers around, you've got the first ingredient for a mobile. Using photos, homemade pictures, or any other paper items, punch a hole in them and tie a string or piece of yarn in the hole. Tie the other end of the string on the wire hanger, spacing three across the bottom of the hanger. If you really want to get creative, hook two other wire hangers on the bottom corners of the first hanger for an even bigger, more inventive mobile.

Love crafting? [Get tons of ideas »](#)

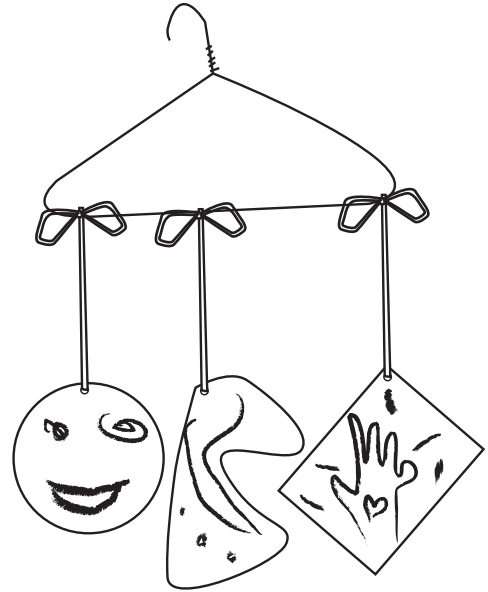

#11 Invent a Dessert Together

Raid the pantry for creative dessert ideas to satisfy the grandkids' sweet tooth. Kids love assembly-line projects – homemade ice cream sandwiches with graham crackers or an ice cream sundae bar with a selection of nuts, granola, and fresh fruit. Consider the season, and use whatever is ripe and available as the basis for a fruity treat. If you don't feel like fussing with a pie crust, make a cobbler or a crumble.

Love cooking with kids? Check out all the fun ideas we have in our [Kids Cooking](#) section!

#12 Create a Collage

Making a photo collage is a great way to honor an event. Many discount stores sell low-cost frames that feature multiple picture holders just for collages.

TIP: Personalize it! For example, if the photos are from a wedding, include the invitation, a napkin, and the wedding announcement from the local newspaper.

A field guide to more smiles,
more fun, more memories.



grandparents.comSM
it's great to be grand.

#13 Take a Firehouse Tour

Call your local firehouse and ask *nicely* if the crew conducts tours. Bring a box of cookies as a gift. Can't get in?

[Tour a factory together »](#)

TIP: Have your grandchild write or draw a thank-you note and send it to the squadron. The firefighters will appreciate it.

#14 How to Tie a Tie

It's a rite of passage handed down within families. And, let's face it, you're not ready to go out on the town unless your tie is tied properly. Perhaps the quickest and easiest is the four-in-hand knot. Place the tie around your neck. Make sure the wide end of the tie is about 12 inches below the narrow end. Follow the diagram on the right to make sure you get it right.

There are so many simple things you can teach your grandchildren that they will love. [To prove it, here are 100! »](#)

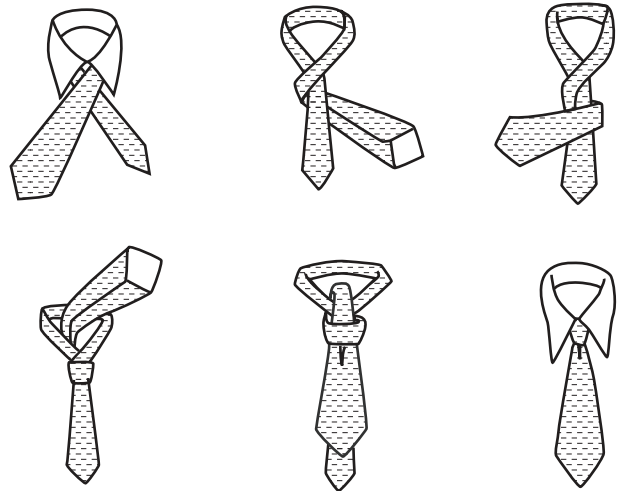

FUN FACT: Oscar Wilde once said, "A well-tied tie is the first serious step in life."

#15 Play Along With a Game Show

Are you really smarter than a fifth-grader? Here's your chance to find out. Play along with a game show on TV and go head-to-head with your grandchild. *Jeopardy!* and the annual *Jeopardy! Teen Tournament* are musts. Right now: Take our [Kids Pop Culture Photo Quiz](#) together.

FUN FACT: The first game show broadcast on TV was Truth or Consequences in 1941.

A field guide to more smiles,
more fun, more memories.



grandparents.comSM
it's great to be grand.

#16 Take a Hike

More and more, grandparents are joining their grandchildren in getting outdoors and staying fit. A [hike](#) is a good way to do just that as well as to spend time together.

[Get tons of ideas for outdoor play »](#)

TIP: The American Hiking Society says to take the following on any hike: a map, compass, whistle, water, food, rain gear, and extra clothes.

Also pack a fire-starter and matches, first-aid kit, knife or multipurpose tool, flashlight and extra batteries, and sunscreen and sunglasses.

#17 Craft-Stick Box

Every little trinket needs a place to go. Have your grandchildren make their own box out of craft sticks. You'll need about 60 sticks and nontoxic wood glue. Start with the base of the box by lining up 10 sticks, vertically. Glue one stick horizontally across the top, and another across the bottom. Glue a third one perpendicular to the first two, adhering it to their edges. Glue a fourth stick on the opposite side. Start building the walls by gluing on an additional horizontal stick on top of the ones you've already pasted, adding one to each side at a time, alternating until the walls of the box have been built to whatever depth you prefer.

TIP: The kids might want to paint each individual stick a different color, and it's easier to paint first and let the sticks dry before putting it all together.

#18 Shadow Puppets

Show grandkids the best dog or bird shadow you perfected as a kid. Challenge each other to see who can make other animals or figures. Let your imaginations take over. This is a fun activity to do when you tuck them in for bed.

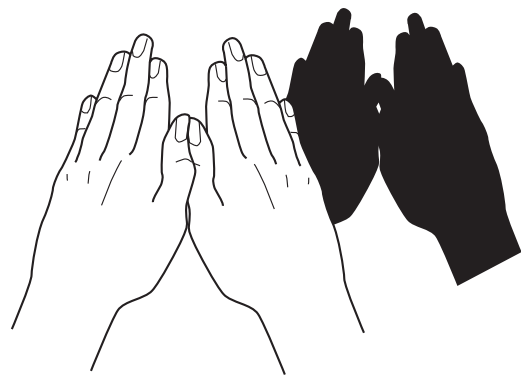

A field guide to more smiles,
more fun, more memories.



grandparents.comSM
it's great to be grand.

#19 Cut Up Pillowcases for Costumes



Your natural reaction is probably not to ruin perfectly good pillowcases. But they happen to make great costumes, such as a superhero, ghost, domino, playing card, Greek goddess or warrior, and more.

TIP: Glue on felt pieces for the pattern instead of using markers. The costume will look cooler.

#20 Play Pretend Store

Setting up a room to resemble a supermarket and having your grandchildren “shop” for items is easy and a great way to teach them a variety of lessons – from shapes and colors and sizes, to various food groups and healthy food choices, to addition and subtraction and the value of money.

TIP: To make it even more fun, create “coupons” that allow the children two-for-one deals, or other discounts.

#21 Download an iPod Walking Tour

Make your next walk together more interesting. Look online to find an audio walking tour in your area and download it onto your iPods and iPhones. You can listen to the same thing and learn at the same time. You’ll both find out about historic buildings, neighborhoods, or museums in your area that you may have never known existed. Two great websites to try: tourcaster.com and audible.com.

CHITCHAT:

What walking tour did you take?

What did you see?

What did you learn from the walking tour?

Find fun tours to take in your area with our [City Guides](#).

A field guide to more smiles,
more fun, more memories.



grandparents.comSM
it's great to be grand.

#22 Tongue Twisters

How much wood would a woodchuck chuck if a woodchuck could chuck wood? We have no idea. We're still trying to figure out why Peter Piper picked a peck of pickled peppers.

CHITCHAT:

How many tongue twisters can you memorize?

Which one was the easiest one to say?

Which one was the most difficult?

#23 Make a Comic Book

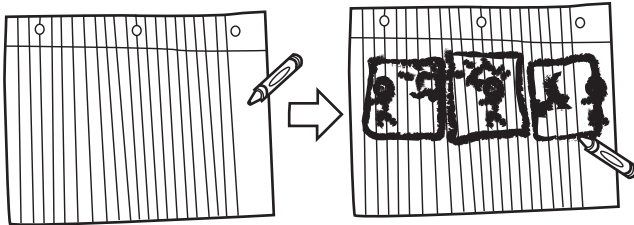

Take a piece of paper and draw three equal boxes or panels. Talk with your grandchildren about creating a story, either about their lives, school, or the family pet. Explain to them that the premise of the three boxes is to help illustrate the story.

TIP: Particularly for younger children, introduce them to the comic section of the Sunday newspaper.

#24 Life-Size Me

Van Gogh, Rembrandt, da Vinci ... all the great artists drew a self-portrait at one point in their lives, so why not you and your grandchildren? Spread a large roll of paper out on the floor and have your grandchild lie down on it. Trace them using a black marker. Then switch, and have your grandchild trace you. Grab a mirror, gaze longingly, and fill in the features of your face with crayons or markers. Color in the clothing, and then hang the picture on a wall or door.

TIP: If you're out of brown shipping paper, pick up an inexpensive roll of newsprint at your local craft store.

A field guide to more smiles,
more fun, more memories.



grandparents.comSM
it's great to be grand.

Want more?



The **Grandparents.com FREE** newsletter is packed with even more fun **things to do**, plus **expert advice**, **toy and gift ideas**, **great deals**, and more.

Get our FREE newsletter!
Go to grandparents.com/newsletter

#25 Visit the Library

Children should know how to use and navigate their local library at an early age, from borrowing books and DVDs to understanding how they must return the items they borrow. Many libraries have separate movies and storytelling programs for children, particularly on the weekends.

Want more? Read about [all the things kids can do at libraries now](#) »

#26 Learn a New Card Game: Rummy 500

Rummy 500 uses a standard 52-card deck and is played with anywhere from two to eight people (some players use two decks of cards when playing with more than four people). The object of the game is to score points by grouping and laying off cards just like in regular rummy, in matched sets of three or four, and in sequences of three or more cards of the same suit. Points are determined by the face value of the cards. The first player to reach 500 points wins the game.

Get the full rules to [Rummy 500](#), [Gin Rummy](#), [Rummy](#), and [24 other card games](#) »

TIP: Like in regular Gin Rummy, you lose points when another player goes out. Make sure you don't get caught with too many big cards in your hand.

#27 Thumb Wrestling

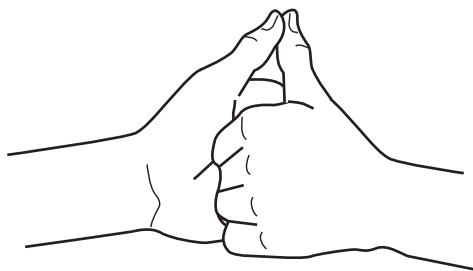

You know the drill. Hook four fingers of one hand together with four fingers of an opponent's hand and clasp tightly. After a countdown, try to pin your opponent's thumb with your thumb.

TIP: Double-jointed in the thumb? You have a distinct advantage in the retreat mode.

A field guide to more smiles,
more fun, more memories.



grandparents.comSM
it's great to be grand.

#28 Make Sock Puppets

Lost a sock in the dryer? Great! Now you can use the other one to make a sock puppet. Any old thing around the house instantly becomes an item to be used for your sock puppet. Glue on old buttons for two eyes (they don't have to match), some yarn for hair, felt scraps for eyebrows, and you're ready for a puppet show ([see #7](#)).

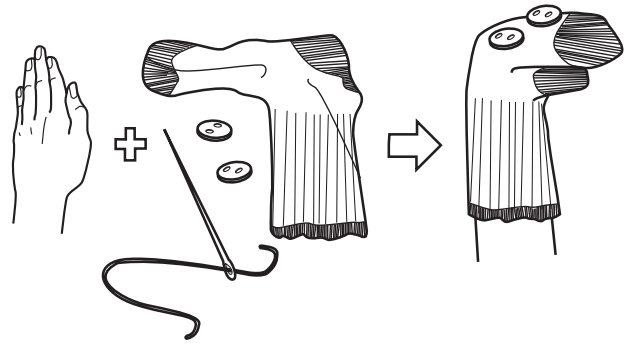

FUN FACT: Some of the most famous sock puppets of all were on The Shari Lewis Show: Lamb Chop, Charlie Horse, and Hush Puppy.

#29 Play Hot Lava

Kids love this game of imaginary adventure where players pretend they are escaping an active volcano. Randomly place pillow cases, dish towels, newspaper, or any mats you have around the floor. Work your way across the room, jumping and leaping from place to place, making sure not to touch the "hot lava" (the floor). You will increase your heart rate as you challenge the kids to see who can cross the room first. This game also helps kids develop spatial awareness as they learn to control their body tempo and movement.

BE ACTIVE TOGETHER: Find more ways to [get kids moving](#) »

#30 Decoupage

Decoupage is the fancy term for taking paper cutouts (your pictures, pictures from magazines, or colorful wrapping paper) and sealing them to a surface. Wipe down and clean the surface you'll be using. Place the cutouts on the surface in whatever pattern suits your fancy, then remove them and set aside. Apply a small amount of glue on the surface and spread it out with a paint brush. Place the photos face up on the glue-covered surface and smooth them out with your hand, working from the center to the outer edges. Let the cutouts dry for a few hours, then apply a few coats of decoupage medium or clear varnish to the finished surface on top of the photos. Note that every time you apply a coat of varnish, you must allow the surface to dry before applying another coat. Add a final coat of acrylic sealant, such as Clear Coat.

A field guide to more smiles,
more fun, more memories.



grandparents.comSM
it's great to be grand.

#31 Have a Staring Contest

No laughing, no poking, no nodding, no blinking ... just staring into the eyes of your opponent to see who flinches first.

CHITCHAT:

Whom did you have the staring contest against?

Who blinked first?

How long did it take?

#32 Make Your Own Puzzle

It's not a jigsaw puzzle, but it's pretty cool nonetheless. Take 20 to 30 flat craft sticks and place them side by side. You can add two or three rows of 20 to 30 sticks each. Now take masking tape and completely cover one side of the sticks, using several pieces of tape. Turn it all over so that the tape is on the bottom. Have the children paint or draw a picture on what is now your wooden canvas. When it dries, take the masking tape off, mix up all the sticks, and try to put it back together again so that you have your picture.

Do you have everything you need for crafty fun? Make sure you have all the basics with our checklist for [stocking your crafting pantry](#).

#33 Water Balloons

No need to explain this one.
Fill. Tie. Throw. Repeat.

[Get hundreds of fun summer ideas »](#)

TIP: Have a water balloon catch. Toss the balloon back and forth, and gradually increase the distance between you and your grandchild. See how far apart you can stand before it bursts.

A field guide to more smiles,
more fun, more memories.



grandparents.comSM
it's great to be grand.

#34 Make Paper Bag Puppets

Make a plain brown lunch bag into any kind of puppet with a little imagination. Simply turn the bag upside down and, using markers, crayons, and glued-on items, create a character of your own.

FUN FACT: In 1852, Frenchman Francis Wolle invented a paper bag-making machine that cranked out the little brown bags in mass quantities.

#35 Walk Dogs at a Shelter

Volunteerism comes from the heart, and it's never too early to teach your grandchildren about the importance of **giving their time to the community**. Many dog shelters welcome volunteers to help walk the dogs and clean the runs and cages. However, before you mention anything to your grandchildren, call your local shelter to see if they accept volunteers and whether there's an age minimum.

#36 Juice Pops

Is there a better summer treat than an ice pop? And you don't even have to go to the store or wait for the ice cream truck to enjoy one. Fill an ice-cube tray with your favorite fruit juice. Cover the tray with aluminum foil, and poke wooden pop sticks through the foil into each cube (the foil helps the sticks stay upright). Place the tray in the freezer. The next day, enjoy the treat.

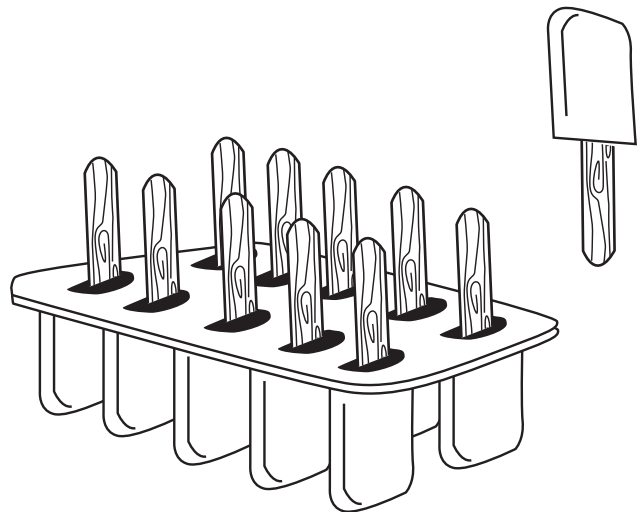

A field guide to more smiles,
more fun, more memories.



grandparents.comSM
it's great to be grand.

#37 Pasta Necklace

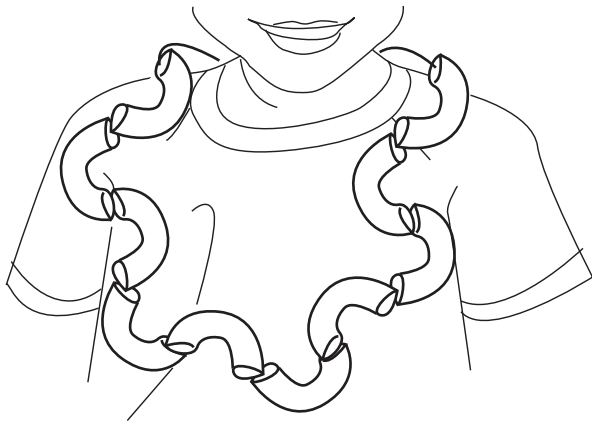

Who among us hasn't worn a necklace made of macaroni? For this one, cut a piece of string or yarn 16 inches long for each child. Go to the pantry and pluck out a box of penne or elbow macaroni, as well as a box of pinwheel pasta. Over newspaper, have the children use nontoxic paint or markers to color the pasta pieces. When dry, put ten pieces of penne or macaroni onto the string, followed by one piece of pinwheel pasta – which serves as the pendant – and then ten more pieces of penne or macaroni. Tie the ends together in a double knot and you have your new fashion statement.

#38 Old Jewelry to New Jewelry

Okay, this isn't MacGyver, who can make a walkie-talkie out of a paper clip, a hanger, and a spoon. But you can use old jewelry parts – or some other items in the house – to make new jewelry. For example, if you have an old pin that's withered away, glue the old pin back to a fancy, colored button to create a new look.

TIP: A fun way to make jewelry is to use seashells. Create these amazing [seashell crafts they'll love](#) »

#39 Dress Up

Years-old dresses, leisure suits, feather boas ... they might be ten sizes too big for your grandchildren but you can bet they'll want to strut around in them.

TIP: Everything old is new again. Those clothes you haven't worn since the 1960s? We bet your teen grandchildren will think they're hip and get some real use out of them.

A field guide to more smiles,
more fun, more memories.



grandparents.comSM
it's great to be grand.

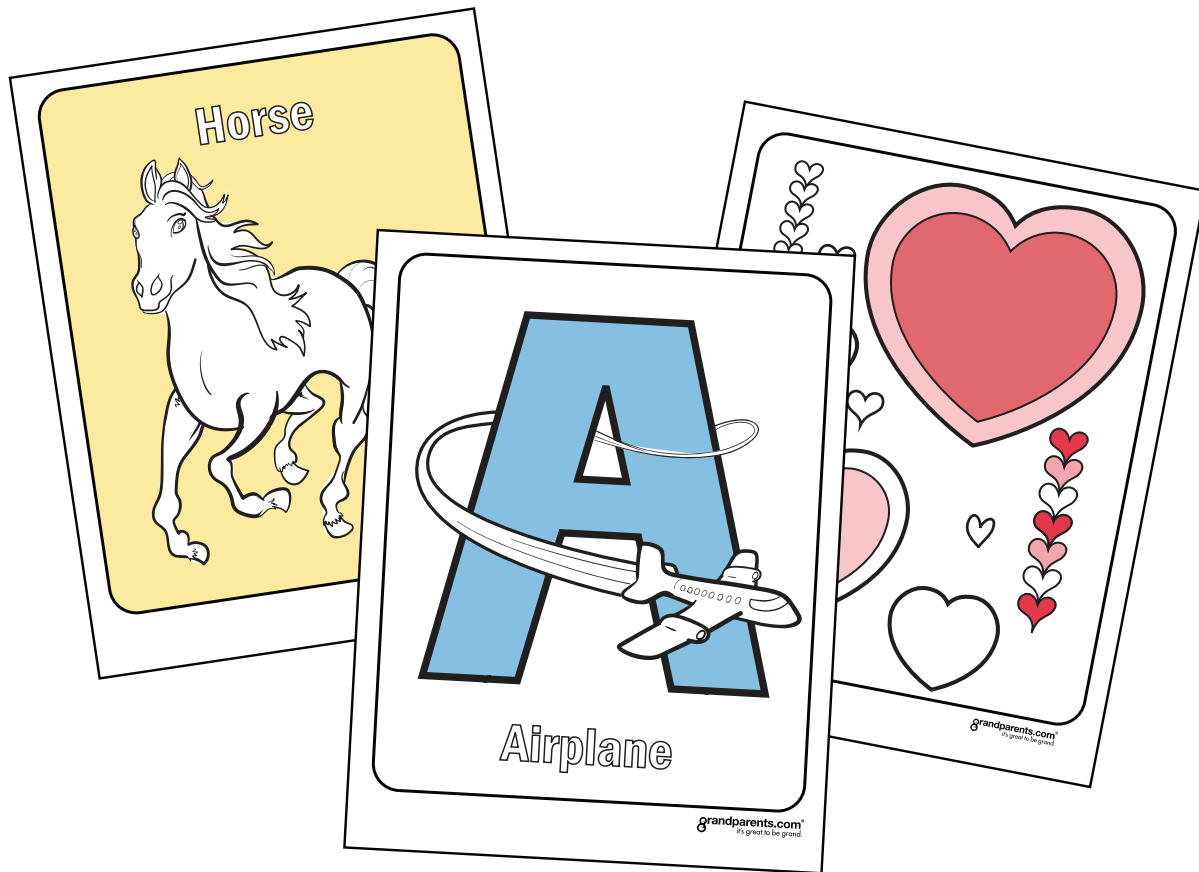

Get More Than 100 **FREE** Coloring Pages

Color animals, ABCs, holidays, and lots more for hours of fun!

Grab your crayons: [grandparents.com/coloring](https://www.grandparents.com/coloring)

#40 Shoebox Diorama

A diorama is a small model of a real-life scene that includes lifelike details and a background. The great thing about this project is that the diorama can be anything your grandchild imagines. If it's a baseball diorama, stand the shoebox upright, paint the lower half of the backside green, the upper half blue, and glue on some cotton balls for clouds. Use paint to make small dots on either side of the shoe box to represent the fans in the stands, and place a figure in the middle as the pitcher.

#41 Terrarium

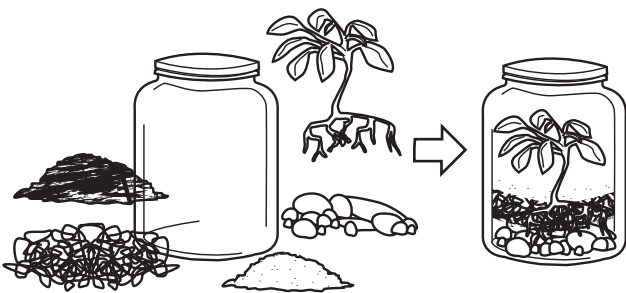

A terrarium is a sort of living landscape inside an enclosed plastic container or jug. To start, put a layer of pebbles or charcoal at the bottom of the container for drainage. Cover that with two inches of topsoil. Add a few rocks, some twigs or branches, moss, and small plants. Moisten the terrarium with water, but don't overdo it. Cover the opening with a sheet of plastic wrap.

TIP: You can add worms or bugs to your terrarium, but make sure that you cover the opening with a screen or stocking instead of the plastic wrap.

#42 Make Bubble Bath

What's better than having kids conduct a little experiment, and then getting to sample their creation? In a bottle – it can be anything from a decorative piece to an old shampoo bottle – pour clear, nontoxic liquid soap until the bottle is three-quarters filled. Have the kids pick their favorite color, and add that food coloring in a few drops at a time. Stir gently. For a scented bubble bath, have them add some oils, such as lavender.

TIP: Print out a label – Alex's Special Bubble Bath – and tell your grandchild it will be waiting for her the next time she comes to visit. Get more ideas for [making bath time special](#) »

A field guide to more smiles,
more fun, more memories.



grandparents.comSM
it's great to be grand.

#43 Make Music With a Wine Glass

An empty crystal wine glass or champagne flute works best for this. Hold the glass as far down on the base of the stem as you can. Do not hold it on the flat bottom. Dip the index finger of your other hand into a glass of water. Take that finger and lightly rub it along the rim of your empty wine glass. This should produce a humming sound. The more you practice, the more you'll get a feel for how light or hard you should rub your finger on the glass to produce different sounds. You'll be making beautiful music together in no time. [3 more musical instruments to make »](#)

#44 Create a Family Newspaper

Call it the *Smith Daily News*, or the *Jones Times*. Most word-processing software comes with newsletter templates. You just provide the news, such as Joey's accomplishments in a Little-League game, or Natalie's A on a big science project, and let the kids write it up. On deadline!

#45 Make Masks

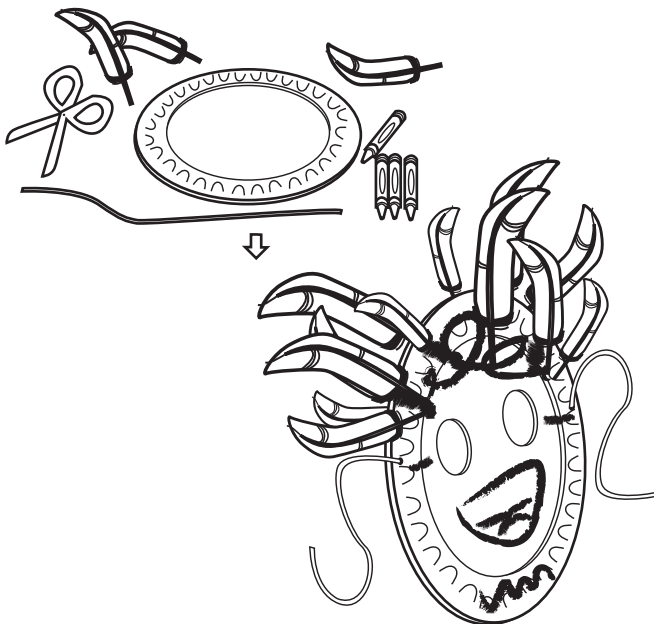

Using a white paper plate, make a funny face or a primitive mask with just a pair of scissors and some crayons. Cut holes where your eyes will go. If you've got some yarn around, add it on as hair or a beard. Put two small holes on either side of the paper plate, and thread some yarn through it to tie the mask to the child's head.

A field guide to more smiles,
more fun, more memories.

100
FREE
things to do
with your
grandkids

grandparents.comSM
it's great to be grand.

#46 Spoon on the Nose Trick

This is one of the all-time great party tricks. Any nose and spoon will do. Breathe heavily on the spoon, or lick it (ewww!). Place it on the edge of your nose. Sounds easier than it really is.

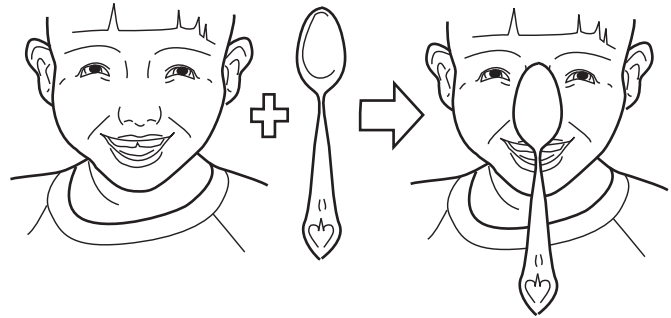

TIP: Don't slobber on the spoon. You want it to be moist, not dripping.

#47 Get a Green Thumb



What child doesn't like getting his hands dirty? Even if you start with the traditional seedling in dirt in a small paper cup, creating a garden of flowers or vegetables is a great way to teach your grandchildren about the environment.

Get fun ideas for [gardening with kids](#) »

#48 Palindromes

And you thought tongue twisters were tough? Challenge your grandchildren – and yourself – to come up with a bunch of palindromes. A palindrome is a word or phrase, like “mom,” that reads the same in either direction. Of course, mom is an easy one. Try coming up with a phrase such as, “Was it a rat I saw?”

WANT MORE WORD FUN? Get the rules to 10 word games you and the kids can play anywhere! [Celebrity, Ghost, Last Letter](#) »

A field guide to more smiles,
more fun, more memories.



[grandparents.com](#)SM
it's great to be grand.

#49 Go Sledding

Remember the Flexible Flyer? Nowadays, kids' sleds have names like King Size Snow Racer and Snow Flyer Deluxe, among others. But the Flexible Flyer is still being made, and it's still the best darn sled out there, in our humble opinion, with the toboggan a close second. Don't have a sled? Try an unbreakable bowl (for a small child). Or, remove the handles and wheels from a wheelbarrow and use the tub. Or, use a trash can lid. In a pinch, you could always tape duct tape in vertical strips to the back and, er, backsides of your grandchildren's snowsuits.

TIP: Choose a hill that's spacious and away from anything dangerous like trees, utility poles, water, and roads.

#50 Take an Alphabet Walk

We all know that walking is good for your physical health. Why not make it a terrific activity for your grandchild's academic health? Have her practice the alphabet and identify with her surroundings at the same time. The Alphabet Walk can be played two ways. Pick a letter of the alphabet and try to find as many things on your walk that begin with that letter (bird, bush, bakery, etc.). Or, use the entire alphabet and try to find something during your walk that begins with every letter (apple, boy, car, dog, etc.).

#51 Explore the Secrets of a Dollar Bill

Did you know a dollar bill has hidden pictures, flecks of color, and mysterious symbols? And that's just the beginning. What do all those seemingly random letters and Latin phrases mean, anyway? A dollar is worth far more than you realize – it's a chance to teach your grandkids something really cool. See if you can find the tiny hidden "owl" (some say it is a spider) next to the large "1" on the upper right of the face of the bill. If you look at the shield shape that surrounds that "1," the tiny owl rests on the top left corner. For more secrets, read the full article. [Amazing facts about the dollar bill »](#)

A field guide to more smiles,
more fun, more memories.



grandparents.comSM
it's great to be grand.

#52 Make Place Mats

You can make place mats with one photo or a series of photos. Let the children pick out the pictures. Arrange the pictures on a piece of colored construction paper, and settle on a design before gluing the photos down. Let the mats dry, then protect them with contact paper or have them laminated. Voila! Personalized place mats.

TIP: Get doubles of the pictures you're using for the place mats so you don't end up eating on the only copy of your favorite picture.

#53 Make a Coaster

Start with the lid of a margarine or yogurt container and a favorite photo. Cut the photo to fit the top of the lid and glue it down. After the glue dries, seal your new coaster with a water-based sealer. Glue cork to the bottom of the lid to give the coaster a solid base.

TIP: Make a different one for every family member and present them at the next dinner.

#54 Make Noisemakers Out of Paper Plates

Take two paper plates and decorate them with streamers or anything else that's fairly light in weight. Put one paper plate on the table, right side up. Place the other plate on top, right side down. Begin taping or stapling the edges together, leaving a small opening on the top to fill with dried beans, uncooked rice, or popcorn kernels. Finish stapling or taping and make some noise!

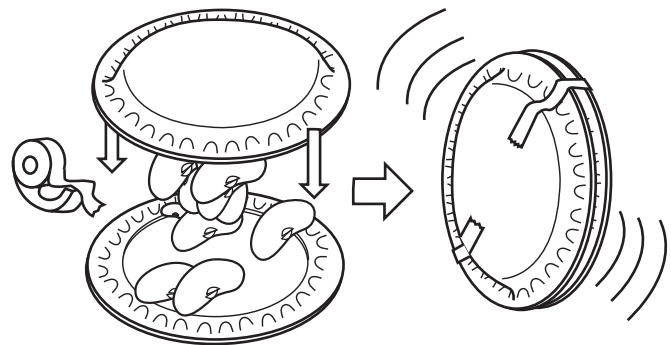

A field guide to more smiles,
more fun, more memories.



grandparents.comSM
it's great to be grand.

75 FREE Kids' Games

Get the official rules to classic kids' games (so you can play them the right way!) including:



Card Games

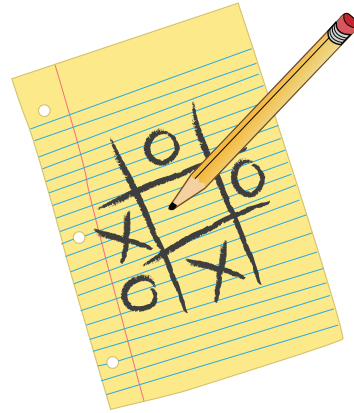

Pen & Paper Games



Word Games

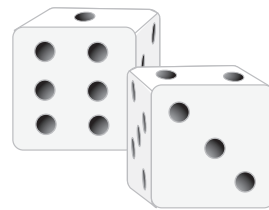

Dice Games

Plus Outdoor Games ... and more!

Get them FREE: grandparents.com/games

#55 It's All About You

This is a fun game that gives you and your grandchildren a chance to get to know each other even better. Take an index card and write down two truths and one lie about yourself. Each player has to guess which statement is NOT true about the other. [Get the full rules »](#)

#56 Play Croquet

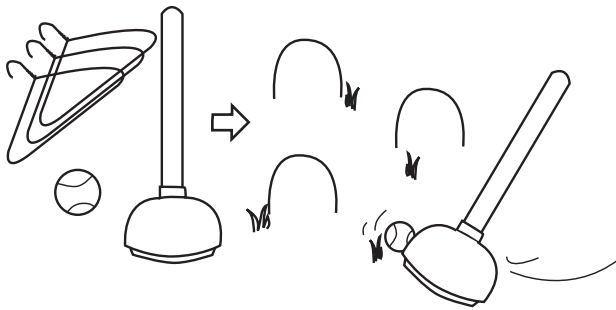

MORE: [Try these other outdoor games »](#)

What was once an Olympic sport is now mainly a backyard recreational activity. Rummage through the garage to see if you have the classic set, which includes the wooden mallet, the wooden balls, and the wickets that are embedded in the grass. If you don't have the equipment, you can always improvise. The wooden balls can be replaced by small rubber or plastic balls. The mallet can be a garden-variety plunger found in most bathrooms. Create the wickets by untwisting wire hangers and sticking them in the ground.

#57 Make Your Own Colored Clay

Why buy it when you can make it?

- 4 cups flour
- 2 cups salt
- 2 teaspoons food coloring
- 4 cups of hot water
- 4 tablespoons cooking oil
- 4 tablespoons cream of tartar

TIP: Store the clay, covered, in the refrigerator to prevent mold.

Mix flour, salt, and water (to which you've added the food coloring) in a large pan and heat over medium heat, adding the four tablespoons of cooking oil and cream of tartar. (The cream of tartar stops the clay from cracking.) Stir constantly until the clay feels like mashed potatoes. Take the pan off the stove and let the clay cool to the point where your grandchildren can knead it until it's smooth. Store in an airtight container.

A field guide to more smiles,
more fun, more memories.



[grandparents.com](#)SM
it's great to be grand.

#58 Make Water in the Desert

The chances you'll be stranded in the desert are remote, but this is nonetheless another classic experiment for children. Dig a large hole in the ground, at least three feet wide by three feet deep. Dig a small hole inside the large hole. In the small hole, place a container such as a coffee can or canteen. Place a large plastic sheet or plastic wrap over the large hole, using large rocks or other heavy objects to keep it tightly in place. Put a small- to medium-size rock in the center of the plastic sheet so that the middle of the sheet dips down right above the coffee can. But make sure the other heavy rocks keep the sheet tightly in place over the hole. The heat of the sun and the moistness of the ground under your sheet will make condensation that should drip right into the coffee can.

#59 Make a Battery Out of a Potato

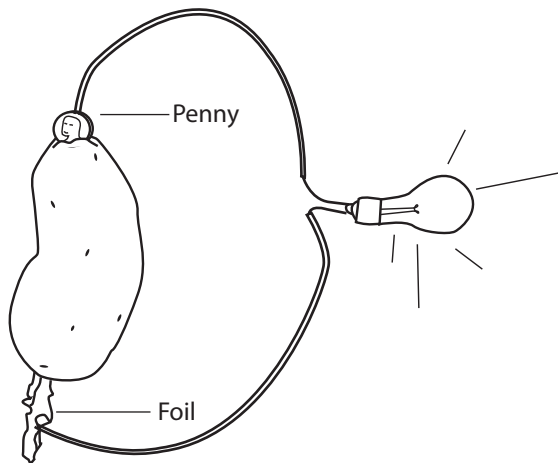

Use sandpaper or steel wool to scuff a nail and a penny until they're shiny. Push the nail and the penny into opposite ends of a potato, wrapping the nail in tin foil. Attach two copper wires, one to the nail and one to the penny. Attach the other ends of the copper wires to the positive and negative signs of a typical battery-operated alarm clock or small lightbulb. You may have to rearrange the wires if nothing happens at first.

#60 Play Marco Polo

Marco!
Polo!

It's the game of [Tag](#) or [Blind Man's Bluff](#) played in a swimming pool. Don't forget: If you get caught leaving the pool by the person who's "It," you're the fish out of water and you're now "It." [Get the full rules »](#)

FUN FACT: No one really knows why this game was named after the Venetian explorer, who introduced Asia to Europe.

A field guide to more smiles,
more fun, more memories.



grandparents.comSM
it's great to be grand.

#61 Cook Using Only Found Items

Hey, they do it on *Iron Chef*. The secret ingredient is whatever you and your grandchild happen to find in the freezer or the pantry. Got a couple of boxes of macaroni, but no tomato sauce? Break out the basil leaves, the olive oil, salt, pepper, and pine nuts or walnuts, and make a pesto sauce. Got chopped meat but no buns for burgers? Can you say, meat loaf?

NEED INSPIRATION? Get ideas for [kid-friendly recipes](#) »

#62 Use Tools

Encourage your budding Bob the Builder by allowing him or her to help you on a project. We're not saying bust out the chainsaw, but a few turns of the screwdriver or a stroke of the paintbrush will certainly plant a seed of do-it-yourself satisfaction.

WANT MORE? We have great ideas for [starting a DIY project with your grandkids](#).

#63 Make a Bird Feeder

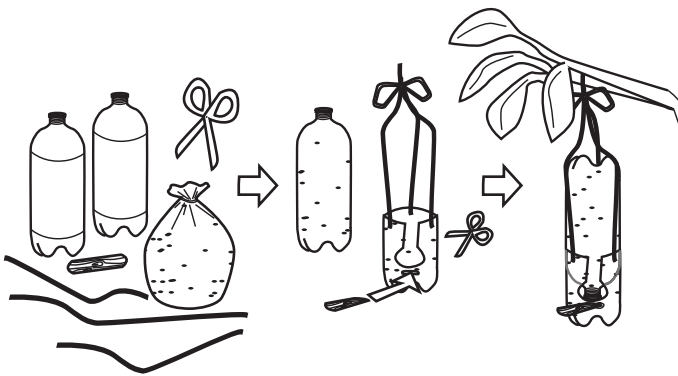

Wash and dry two empty two-liter soda bottles. Cut one of the bottles in half and throw the top half away. Use a knife to poke two or three holes in the bottom half. Now gently poke tinier holes right below those to use as your perches for the birds. Insert toothpicks in those tiny holes and glue them to the bottle. Fill the bottle with birdseed. If you want to hang it, poke three holes in the top of the bottle and, using string threaded through each hole, tie together and hang from a branch. Fill the other bottle with more birdseed and place it upside down in the first bottle, allowing it to refill as the birds munch. [More bird crafts](#) »

A field guide to more smiles,
more fun, more memories.



[grandparents.com](#)SM
it's great to be grand.

#64 Rock Paper Scissors

The ultimate game of strategy and decision-making. Just remember, to immediately quash all disputes, here's how it goes: Rock beats scissors; scissors beats paper; paper beats rock. [Get the full rules »](#)

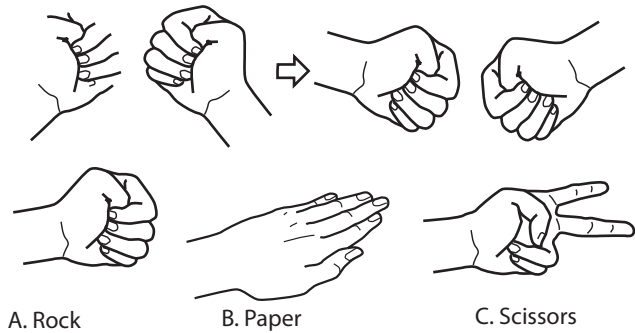

FUN FACT: In 2006, Federal Judge Gregory Presnell from the Middle District of Florida ordered opposing sides in a lengthy court case to settle a trivial (but long-debated) point over the appropriate place for a deposition, using the game of Rock Paper Scissors.

#65 Simon Says

If there was ever a lesson in paying attention to instructions, this game is it. Have fun with the grandchildren as Simon Says to touch your toes, and as Simon Says to raise your right arm, and then to touch your nose. Aha! Gotcha!

FUN FACT: Simon Says started as a game in New York State's Catskill Mountains during its heyday as a resort area, designed to get older women up and exercising.

#66 Catch Fireflies

Is there a more iconic image of a summer night than a bunch of children racing around the backyard to catch fireflies? Also known as lightning bugs or glowworms, fireflies literally light up part of their body momentarily. If you can somehow snare one, put it in an old jelly jar with some grass or leaves, and puncture the top of the jar for air holes.

A field guide to more smiles,
more fun, more memories.



grandparents.comSM
it's great to be grand.

#67 Play a Game of H-O-R-S-E

Head to the local basketball court and try this one. Your grandchild calls out a shot – “reverse layup!” – and if he makes it, you have to do the same. If not, you get an “H.” Whoever gets to H-O-R-S-E first loses. Remember, no dunking.

Don't love hoops? [Try disc golf](#) »

#68 Capture the Flag

Divide players into two teams in an agreed-upon area or territory. Each puts a flag at a chosen home base. The other team must try to capture the opponent's flag without getting tagged and sent to jail for a period of time decided beforehand.

FUN FACT: Capture the Flag is making something of a comeback among adults, who play a more elaborate version on city streets using cell phones and other technology.

#69 Red-Light, Green-Light, 1-2-3

A classic children's game. Have a group of children stand in a horizontal line about 30 feet away from the caller (you?), who acts as the stoplight. The stoplight faces away from the other kids. When the stoplight shouts, “Red-light, green-light, 1, 2, 3. Who do I think I'll see?” the children start running toward him. When the stoplight turns around and faces the group, the children must freeze in place. If the stoplight sees someone moving, that person must go back to the start. This goes on until one child is able to tag the stoplight.

FUN FACT: The first traffic light was a manually operated gas lantern in London, circa 1868.

A field guide to more smiles,
more fun, more memories.



grandparents.comSM
it's great to be grand.



100+ FREE Kids' Sing-Alongs

The lyrics you *almost* remember to:

The Ants Go Marching • Frere Jacques • Hush Little Baby
If You're Happy & You Know It • Mary Had a Little Lamb
On Top of Spaghetti ... and more – FREE!

Start singing: grandparents.com/singalongs

#70 Create Your Own Quizzes

It's a great way to keep your grandchild sharp, especially during summer months, and not a bad way for you to refresh those multiplication tables. For competitive types, give points for each right answer (but don't forget to gear down for the little ones).

#71 Swap Skills

Make plans for a skill-swap day — the kids teach you something, and you teach them something. Consider teaching the kids a classic [card game](#) or how to shuffle cards, while they teach you to play a new video game. Or teach them a simple piano scale, then let them teach you their favorite dance moves. This is a terrific way to strengthen the bond between you and your grandchildren and make memories you both will cherish.

#72 Stand an Egg on Its End

We could get all scientific here and explain how this works. Twice a year – on the autumnal and vernal equinoxes – there is an equal amount of day and night on Earth. At those precise moments, the oblong-shaped egg can stand on one of its ends. With a little patience, of course.

FUN FACT: With a great deal of patience, and time on your hands, you can get an egg to stand on end at a time other than the equinox.

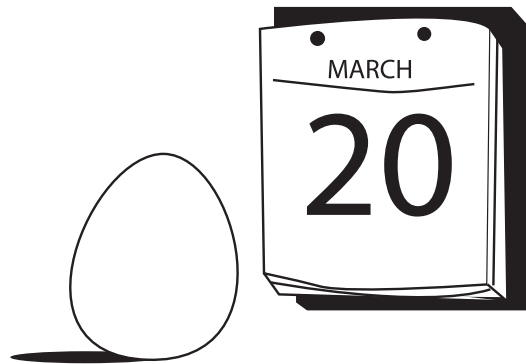

A field guide to more smiles,
more fun, more memories.



[grandparents.com](#)SM
it's great to be grand.

#73 Exquisite Corpse

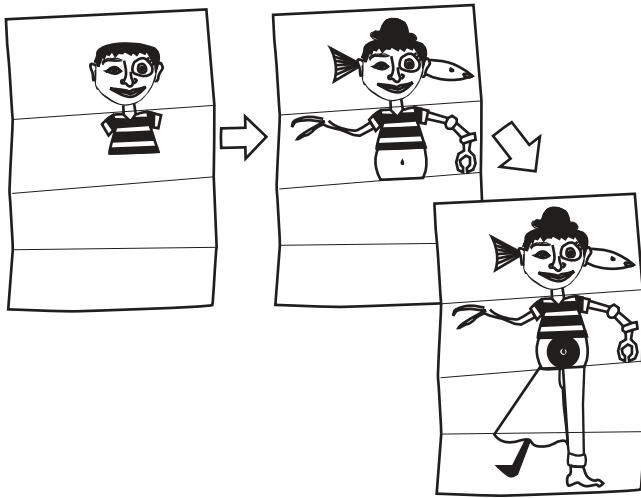

A rather graphic game played with paper and pencil. The title is a misnomer. There's no death involved, just some creative cartooning. Various players start by drawing images or words, folding the paper in a pleat to conceal their work before passing it on to the next person. Two vertical lines above a fold form a neck, so everyone knows where the head should be. The head could be a baseball cap. An arm could be a fish. A leg could be a math equation. And so on, until a surrealist image appears.

#74 Scavenger Hunt

A scavenger hunt is flexible, and you and the grandkids can do it indoors or outdoors. Especially for younger children, give several descriptions of the items they'll be seeking, such as an orange ball, or a pencil with no eraser, or a pillow with fringes. For older children, these can be as elaborate – and difficult – as you want to make them.

FUN FACT: The University of Chicago hosts an annual scavenger hunt that lasts four days.

#75 Create a Story That Keeps on Going

Have one person start out. "One day, I was walking down the street." Then the next person must add to the story. "And I saw a beautiful orange car." And then the next person says, "And a lovely lady was driving it." And the next adds, "She had a most remarkable lion, waving from the back seat." And so on, and so on, and so on. If you're a long-distance grandparent, you can do this by e-mail.

A field guide to more smiles,
more fun, more memories.



grandparents.comSM
it's great to be grand.

#76 Bury Someone in the Sand

A time-honored beach tradition where somebody subjects himself to being completely covered in sand up to his or her neck. Fun! If you're going to the beach, don't forget our [Beach Trip Checklist](#) »

TIP: Uh, don't let your grandchildren stray too far away if you're the one being buried. Once that sand becomes compacted around you, it could be difficult to wriggle free without help.

#77 Make and Bury a Time Capsule



TIP: Write a personal note to include in the capsule.

Using a large jar with a good, tight seal, make a time capsule by filling the jar with items that reflect this moment in time – a newspaper with events of the day; a television guide, to give people an idea of what was on; music CDs; personal photographs, and any other significant items. Bury the time capsule and write down the exact location. Put that piece of paper in the file with your will or in a safety deposit box.

#78 Make Your Own Stickers

First, have your grandchildren get creative and draw any kind of picture or design they want on paper. This can be plain white paper or construction paper, and remember that these are going to be stickers, so the drawing should be smaller than the entire piece of paper. Now carefully cut out the design. Then, turn the paper over and put double-sided tape on the back. To save the sticker, and make it easier to use again, stick it to wax paper for safekeeping.

A field guide to more smiles,
more fun, more memories.



grandparents.comSM
it's great to be grand.

#79 Backward Day

.fun of lot a be can Day Backward, imagination your use you If. Just do everything backward. Write backward, talk backward. Wear your shirt with the back in the front. Eat a steak dinner for breakfast, and pancakes for dinner. Play a board game from the finish line to the start. Whatever you do, just turn it upside down.

FUN FACT: There is a Backward Day and it's celebrated on January 31.

#80 Listen to Vinyl Records

To the younger set, they are ancient curiosities – vinyl discs each with a single, narrow groove winding from the outside rim to the center. Place one on an equally ancient "hi-fi" machine, power it up, place a needle into that groove, and, somehow, you get music. If your stacks of wax have survived their many journeys, it's time to pull them out and invite the grandkids over for hours of intergenerational fun. [How to spin a conversation »](#)

#81 Manicures/Pedicures

Forget the salon or the spa. You have it right in your own home. Break out the nail polish, the cotton balls, emery boards, and toe separators, and enjoy a little pampering with your grandchild. [Get recipes for homemade spa treats »](#)

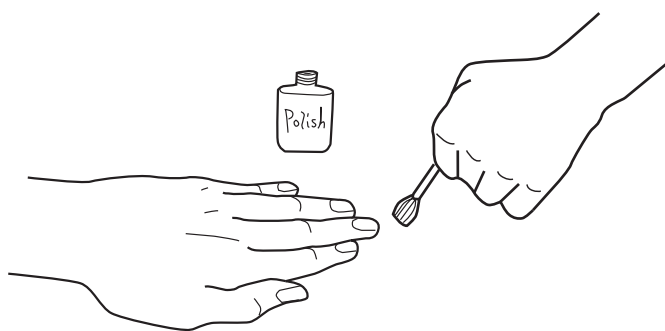

CHITCHAT:

What color did you polish your fingernails?

What color did you polish your toenails?

You know, you can also make each nail a different color and layer polishes!

A field guide to more smiles,
more fun, more memories.



grandparents.comSM
it's great to be grand.

#82 Leaf-Rubbing

On a piece of plain white paper, position a fresh leaf vein side up. Lay another sheet of paper over the top of the leaf. Peel a crayon and gently rub the crayon on its side over the top sheet of paper. The image of the leaf will appear.

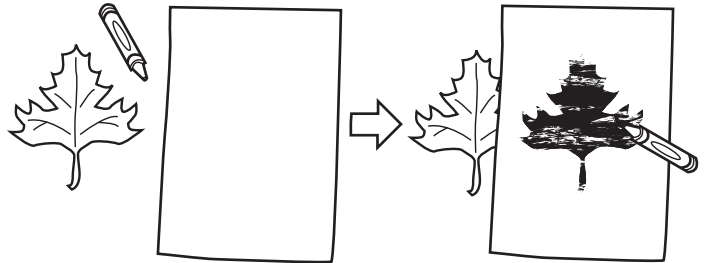

TIP: When collecting leaves, put them in a plastic bag to keep them fresh.

#83 Make a Dandelion Necklace

Remove them from your lawn, and dandelions are actually quite pretty. So why not make one to put around your grandchild's neck? Pick dandelions with long, thick stems. Attach them by tying one stem in a knot high up near the flower of another dandelion, and so on until reaching the desired length.

TIP: Tell your grandchildren that their new necklaces are made of weeds and will wilt in a day or two, but remind them that they can always make a fresh one.
More nature crafts and play »

#84 Redesign Your 'Fridge

What's the most-used room in the house? The kitchen, of course. And what's the most-used appliance in the kitchen? The refrigerator, which is also where all your photos and trinkets end up. Let your grandchildren channel their inner Picasso. Break out the photos and the magnets, and let them design the front of the 'fridge.

Get creative: [9 crafty ways to display kids' art »](#)

A field guide to more smiles,
more fun, more memories.



grandparents.comSM
it's great to be grand.

#85 Play Statues

For this game, you need at least four people, but more people make for more fun. One player acts as the Curator and stands at the opposite end of the playing field from everyone else. When the Curator has his back turned, the players run toward him, trying to be the first to tag him. When the Curator turns to look, the players must freeze in place like statues. Any player caught moving is eliminated. [Get the full rules »](#)

#86 Dig a Hole

Find shovels. Find a patch of grass or dirt. Dig.

Dig it?

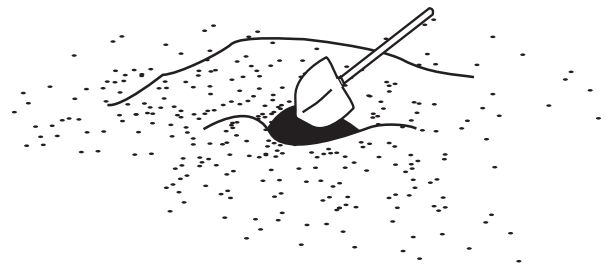

#87 Take Photos

Children already have a great view of life. Now give them a different way of looking at things by introducing them to photography. Whether you have an old Polaroid or a new digital camera, teach them the basics – how to look through the viewfinder, how to keep their fingers away from the lens, what makes for interesting composition, and other tips to make them feel like real shutterbugs. If you use a film camera, call your local college or community center to see if it has a darkroom that's available to the public.

FUN FACT: The first photograph ever developed is generally acknowledged to have been taken in 1826 by Joseph Nicéphore Niépce of France.

A field guide to more smiles,
more fun, more memories.



grandparents.comSM
it's great to be grand.

#88 Dizzy Broom (or Bat) Race

It's a simple race. First, hold a broom or bat in the air, looking at the top of it. Keeping your eye on the top, spin in a circle 10 times. Now (try to) run to the finish line. Hilarity should ensue.

FUN FACT: This game is a staple at Minor-League Baseball parks across the country, where contestants compete for prizes.

#89 Mentos Soda Explosion

This experiment was a YouTube sensation a few years ago. Do it outside. Take the cap off a brand new, two-liter bottle of Diet Coke. Drop a sleeve of Mentos candies into the bottle, step back, and wait for science to take over. The explosion of Diet Coke into the air is pretty cool, and not a bad way to explain how mixing certain things can sometimes have an unexpected effect. Hello, teaching moment.

#90 Vinegar Volcano

This is a classic science experiment, and an easy one. To make the volcano, mix 6 cups flour, 2 cups salt, 4 tablespoons cooking oil, and 2 cups of water. The mixture should be smooth and firm. Stand a large soda bottle in a baking pan or shallow dish, and begin to shape the dough around it. Don't cover the hole and don't drop any of the dough into it. Fill the bottle about three-quarters full with warm water and a few drops of red food coloring. Add 6 drops of liquid detergent to the bottle, and 2 tablespoons of baking soda. Finally, slowly pour vinegar into the bottle and step back!

[More fun science »](#)

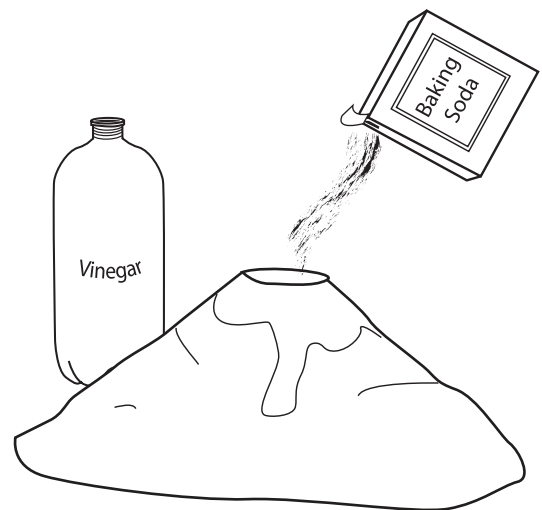

A field guide to more smiles,
more fun, more memories.



grandparents.comSM
it's great to be grand.

#91 Play Hangman

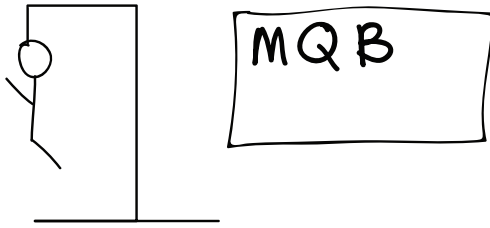

a p p _ e _

One player thinks of a word or phrase and draws a dash for each letter in the word or phrase. The other tries to guess letters in the appropriate blanks. Each time a player misses a letter, a stick figure body part is drawn to a noose. When the head, arms, torso, and legs are drawn, the guesser has lost. [Get the full rules »](#)

FUN FACT: It was this legendary children's game that was the inspiration for TV impresario Merv Griffin to create the game show Wheel of Fortune.

#92 Dance Party

Who says you have to wait for a wedding reception to show off your best moves? Teach your grandchildren The Mashed Potato or The Twist. Then, let them teach you how to pop, lock, and drop it.

FUN FACT: Dancing burns an average of 317 calories per hour in a 155-pound person.

#93 Do a Puzzle

Clear some space on a table and enjoy the timeless tradition of piecing together a jigsaw puzzle. The difficulty level and length of time it takes to complete the puzzle should be appropriate to the age of the child.

TIP: Children will gain a sense of patience and accomplishment. You can save the puzzle by sliding a thin piece of plastic underneath and then brushing two thin coats of clear coat puzzle glue on the puzzle. Allow two to four hours to dry.

A field guide to more smiles,
more fun, more memories.



grandparents.comSM
it's great to be grand.

#94 Cushion Forts

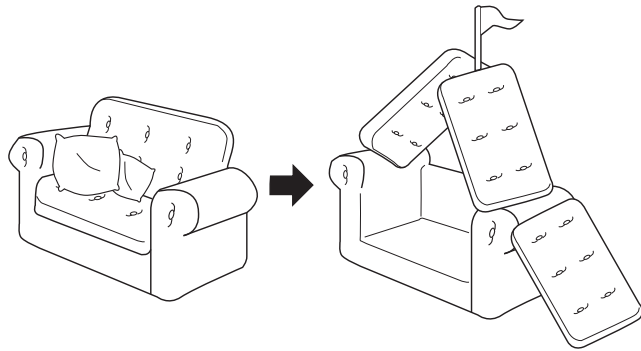

Kids love a secret hiding place to call their very own. On a rainy day, use the cushions of your couch and chairs, old pillows, and a few blankets, and arrange them around the rest of the furniture to create a fort. Leave a space for the all-important tunnel!

TIP: Accessorize! Give the kids flashlights to play with, or let them eat a small (read: not messy) meal in their new fort.

#95 Cardboard Box Forts

Ah, the incredible multipurpose uses of cardboard. Wanna make a fort? Go vertical and stack boxes in a square (creating something of a courtyard). Or, open both ends, lay them down one after the other, and create a tunnel that snakes through the house. Or, go elaborate by getting a big refrigerator box, cutting it so that it opens on three sides, make a small door, and paint the outside to resemble a castle.

#96 Have a Sunday Sundae Party

You can do this on any day of the week, or whenever the mood – craving? – strikes you and your grandchildren. First, get an old tablecloth or sheet to cover your kitchen or dining room table. Next, break out all the fixin's. And we do mean ALL of them: bowls, spoons and napkins; at least four different flavors of ice cream; rainbow and chocolate sprinkles; chocolate chips and raisins; chocolate, caramel, strawberry, and butterscotch sauces; sliced bananas; whipped cream; and, of course, cherries. Create an assembly line that would have made Henry Ford proud.

TIP: Mix in some unusual toppings, such as mochi dough (a popular Japanese mix-in) or your favorite cold cereal.

A field guide to more smiles,
more fun, more memories.



grandparents.comSM
it's great to be grand.

#97 Snow Dots

Bam! Splat! Snow dots are what's left on trees and other targets after firing off a snowball. And if your grandchild leaves a few of these, well, call the Yankees or the Cubs or the Dodgers and get the kid signed to a contract! [29 winter activity ideas »](#)

#98 Make Fudge

Make this gooey treat together.

Ingredients:

- 4 1/2 cups sugar
- 1 13-ounce can evaporated milk
- 1 cup unsalted butter
- 3/4 teaspoon salt
- 3 12-ounce packages semisweet chocolate chips
- 1 7-ounce jar marshmallow creme
- 4 cups chopped pecans (if desired)

Grease a 9-inch by 13-inch glass baking dish. In a large saucepan, combine sugar, evaporated milk, butter, and salt. Mix well. Bring to a boil and reduce the heat to medium. Continue to cook at a low boil for 9 minutes, stirring constantly. Remove the pan from the heat. Immediately, add chocolate chips and stir until melted. Add marshmallow creme, and pecans if desired. Mix well. Pour mixture into the prepared baking dish. Let stand until fudge is set, at least 1 hour.

#99 Snow Angels

Lie down in an undisturbed patch of snow and sweep all four limbs back and forth. Carefully get up and look at the angel you made.

FUN FACT: The world record for the greatest number of snow angels made simultaneously in one place is 8,962, made February 17, 2007 on the grounds of the state capitol in Bismarck, North Dakota.

#100 Tell Jokes

Make 'em laugh! Kids love jokes, and the sillier, the better. Tell your best silly joke and let them tell theirs. Need ideas? We have dozens of [great jokes for kids »](#)

A field guide to more smiles,
more fun, more memories.



grandparents.comSM
it's great to be grand.



Find Something To Do in a City Near You!

Grandparents.com City Guides are packed with 101 activities in 50 U.S. cities – so no matter where you are, you'll never be at a loss for things to do with your grandkids!

Find activities, events, attractions and more:

[grandparents.com/cityguides](https://www.grandparents.com/cityguides)

AN INVITATION:

In creating this work, Grandparents.com compiled a list of many wonderful things for you to do with your grandchildren. We're sure that you have some ideas of your own, and we would love to hear about them so we can share them with other grandparents. Please write us:

E-mail: 100freethings@grandparents.com

Mail: 100 Free Things to Do With Your Grandkids
Grandparents.com, LLC.
24 Union Square East – 5th floor
New York, NY 10003

CREDITS:

EDITORS

Jeff Beil
Susan Avery
Stewart Coerver

COPY EDITOR

Fran Claro

RESEARCHERS

Kai Alexis Smith
Zachary Collinger
Elizabeth Semrai

WRITER

Rich Thomaselli

DESIGNERS

Bryan Rackleff
Sonya Balchandani
Laura Galbraith

SPECIAL THANKS FOR SMART IDEAS AND SUPPORT:

Jackie Albanese, Phoebe Assenza, Beverly Beckham, Marcy Black, Ryan Bogardus, David Brinker, Brian Cochrane, Gary Drevitch, Hayley Friedman, Kara Hatherill, Jonathan Healey, Hannah Kreiswirth, Matt Law, Shelly Lipton, Jose Marin, Molly O'Neill, and Jerry Shereshevsky

PUBLISHED BY:

Grandparents.com, LLC.
24 Union Square East – 5th floor
New York, NY 10003
646-839-8800

Copyright © 2008 Grandparents.com, LLC. All rights reserved.
No part of this publication may be reproduced, stored in a retrieval system or transmitted in any form or by any means, electronic, mechanical, photocopying, recording, scanning or otherwise without the prior written permission of Grandparents.com.

Grandparents.com and the Grandparents.com logo are trademarks of Grandparents.com, LLC.

**A field guide to more smiles,
more fun, more memories.**



grandparents.comSM
it's great to be grand.